

## Lecture 7: Heterodyning (Up & Down Frequency Converter)

Prof. Mohammed Hawa  
Electrical Engineering Department  
The University of Jordan

EE421: Communications I.

### Heterodyne: Multiple Frequencies

- Typical **transmitters** do not modulate immediately from baseband to carrier frequency  $\omega_c$ . Rather, they modulate to an *intermediate frequency*  $\omega_i$ , then an up-converter shifts the frequency to the higher frequency  $\omega_c$ .
- Also, real-life **receivers** do not demodulate immediately from carrier frequency  $\omega_c$  to baseband. Rather, they use a down-converter to shift the modulated signal to an *intermediate frequency*  $\omega_i$ , then demodulate to baseband.
- This has advantages, especially in FDM systems, digital systems and others (*later course*).

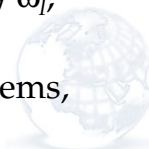

Copyright © Prof. Mohammed Hawa

Electrical Engineering Department, The University of Jordan

2

# Frequency Conversion

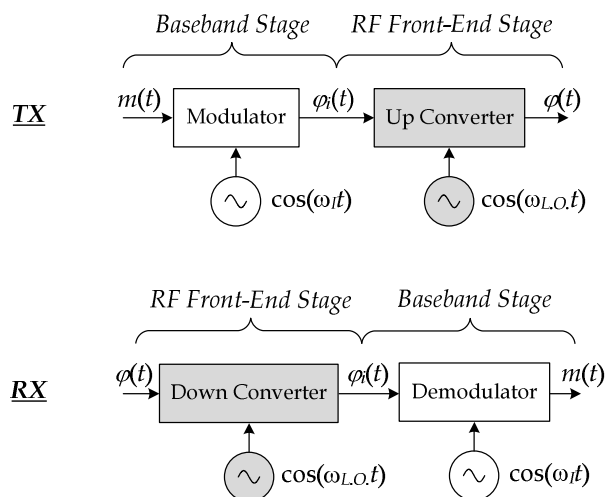

Copyright © Prof. Mohammed Hawa

Electrical Engineering Department, The University of Jordan

3

## Be careful!

- Frequency converter is also commonly called a **mixer**, but do not confuse it with a multiplication device.
- Frequency converter is **not** a demodulator.
- Frequency converter is **not** a modulator.
- **Up converter** takes you from *low* input frequency to *high* output frequency.
- **Down converter** takes you from *high* input frequency to *low* output frequency.

Copyright © Prof. Mohammed Hawa

Electrical Engineering Department, The University of Jordan

4

## Frequency Converter Hardware

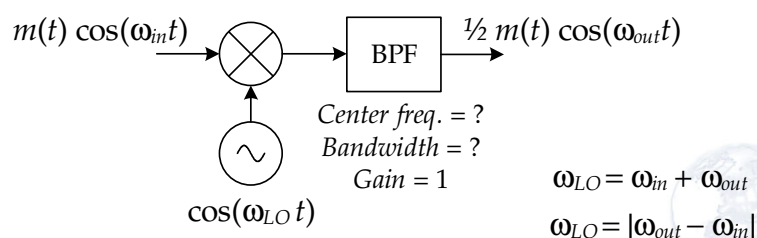
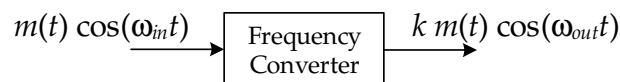

Copyright © Prof. Mohammed Hawa

Electrical Engineering Department, The University of Jordan

5

## Examples

Input frequency $f_{in}$	Output frequency $f_{out}$	Device Type	L.O. frequency
300 MHz	100 MHz	Down converter ( <i>sum</i> )	400 MHz
300 MHz	100 MHz	Down converter ( <i>difference</i> )	200 MHz
100 MHz	300 MHz	Up converter ( <i>sum</i> )	400 MHz
100 MHz	300 MHz	Up converter ( <i>difference</i> )	200 MHz

Copyright © Prof. Mohammed Hawa

Electrical Engineering Department, The University of Jordan

6

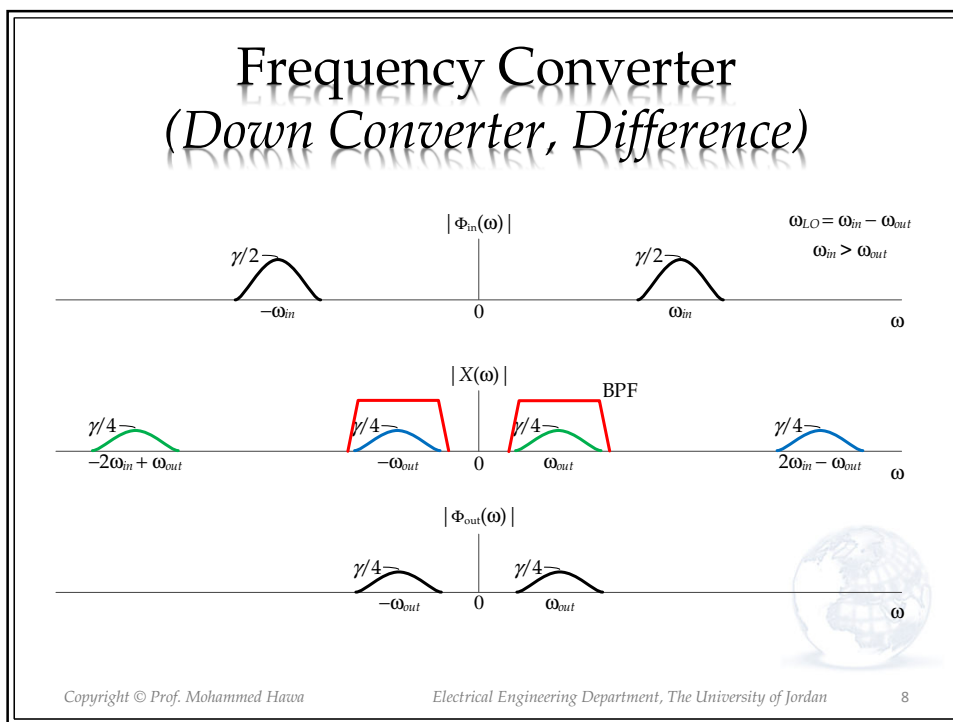
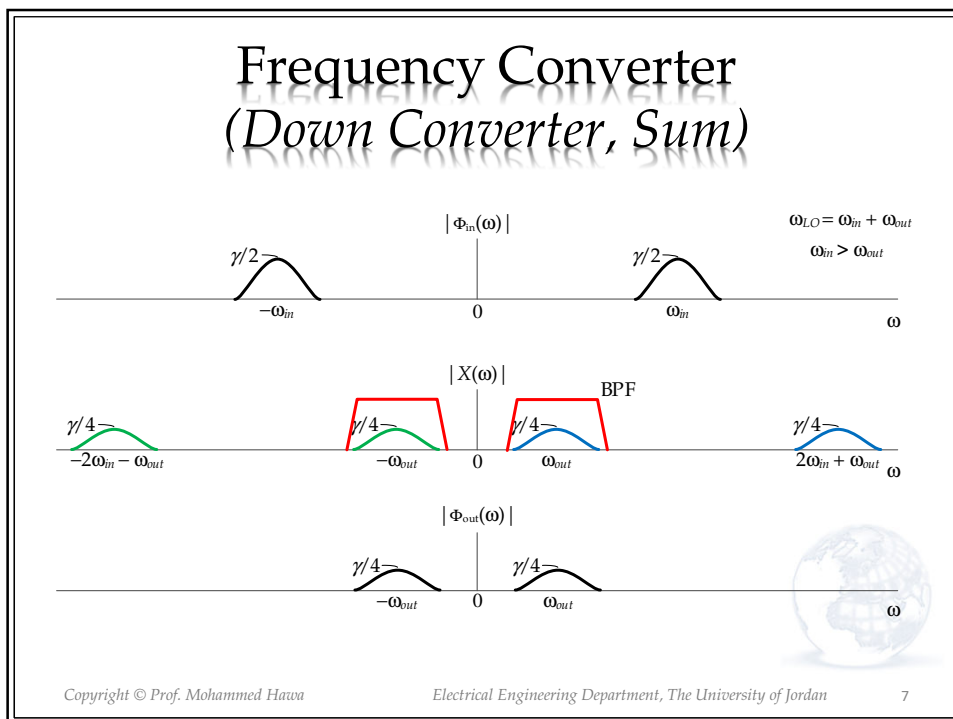

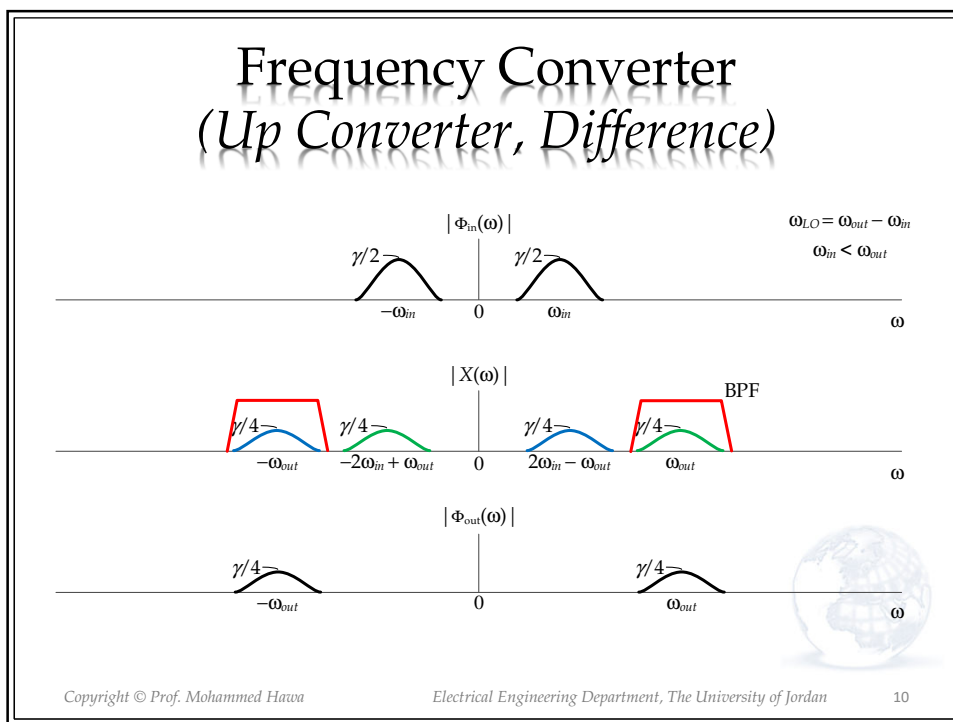
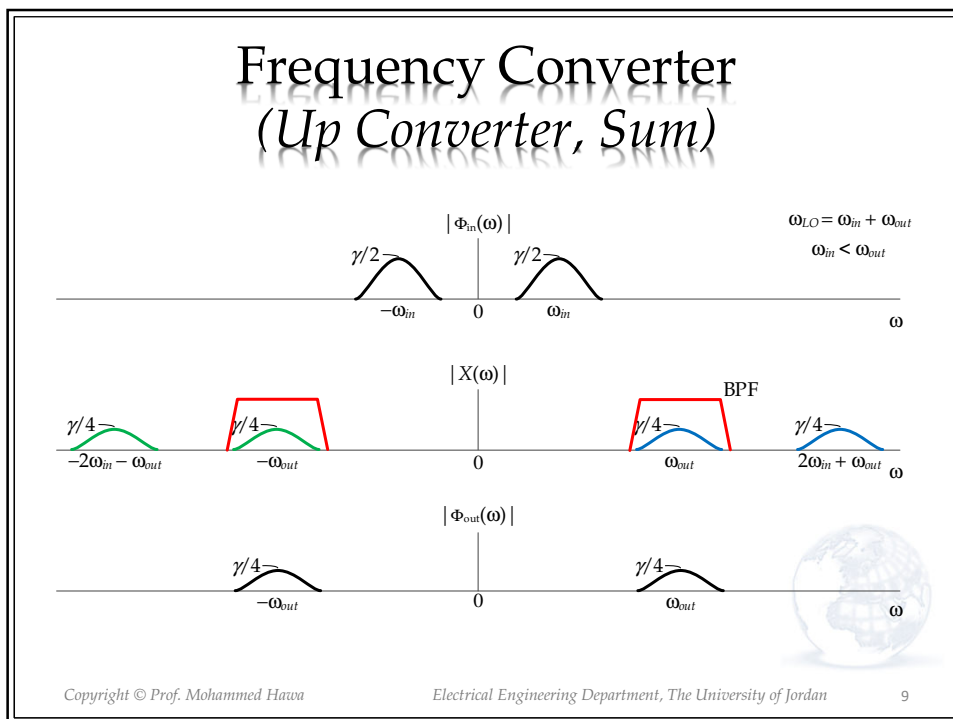

## Homework 1

- Repeat the four cases above for SSB-SC (USB) input modulated signal:
  - Up converter, Sum
  - Up converter, Difference
  - Down converter, Sum
  - Down converter, Difference
- Find  $k$  in the output signal:
 
$$y(t) = k \varphi_{\text{SSB-SC}}(t)$$
- Provide specifications for the BPF to be used.



## Homework 2

- Repeat the four cases above for QAM input modulated signal:
  - Up converter, Sum
  - Up converter, Difference
  - Down converter, Sum
  - Down converter, Difference
- Find  $k$  in the output signal:
 
$$y(t) = k \varphi_{\text{QAM}}(t)$$
- Provide specifications for the BPF to be used.



## Homework 3

- Does the frequency converter (mixer) work if you use  $p(t)$  instead of  $\cos(\omega_{LO}t)$ ?
- If so, what is the necessary frequency(ies) for  $p(t)$ ?
- Find  $k$  in the output signal:  
$$y(t) = k m(t) \cos(\omega_{out}t)$$
- Provide specifications for the BPF to be used.

